

Original Article

Deep Learning-Based Image Processing Approach for Irradiance Estimation in MPPT Control of Photovoltaic Applications

J. Shirisha¹, C. P. Tamil Selvi², S. Saru Priya^{2*}, V. Saravanan^{2*}, B. Sakthivel^{3*}, R. Surendiran^{3#}

¹Department of ECE, Malla Reddy Engineering College, Hyderabad.

²Department of CSE, PPG Institute of Technology, Coimbatore.

^{2*}Department of ECE, Velammal Engineering College, Chennai.

^{3*}Department of ECE, Pandian Saraswathi Yadav Engineering College, Sivagangai.

^{3#} School of Information Science, Annai College of Arts and Science, Kumbakonam, ORCID:0000-0003-1596-7874.

^{3#}Corresponding Author : surendiranmca@gmail.com

Received: 19 July 2022

Revised: 09 September 2022

Accepted: 17 September 2022

Published: 30 September 2022

Abstract - Renewable energy contributes significantly to power generation to tackle the energy demand. Renewable energy is obtained from solar, wind, hydroelectric, etc. Among these, solar energy is considered the best suitable energy in terms of cleanliness and directly converts sunlight into electrical power by solar photovoltaic (PV) module. Solar panels' randomly changing power output due to irradiance is the biggest problem with solar panels. The concept of maximum power point tracking (MPPT) techniques is introduced to tackle this non-linear behavior of PV and optimize the PV system's efficiency. Various MPPT techniques have been proposed based on conventional and intelligent methods. In this work, a novel image processing-based MPPT technique is introduced to increase the efficiency of PV. The irradiance level is accurately classified using the self-learned EfficientNetB0 deep learning model. The parameters of the EfficientNetB0 model are adjusted using Tuna Swarm Optimization. Results show that the tracking efficiency is higher than other intelligent MPPT techniques. Also, the classification accuracy of the proposed learning model is superior to conventional models.

Keywords - MPPT, PV and EfficientNetB0.

1. Introduction

PV systems are cost-effective renewable energy sources used to reduce global warming and reduce the necessity of fossil fuels. The effectiveness of PV is a good alternative to avoid environmental pollution and reduce CO2 emissions. The efficiency of a PV system is greatly affected by the seasonal climate conditions and the non-linear behavior of solar irradiance. The concept of MPPT is used to overcome these issues and improve the PV system's efficiency under partial shading conditions.

The general block of PV-based power generation is shown in Fig 1. The solar-based power system consists of a PV array, DC-DC converter and MPPT controller. The major function of the MPPT controller is to generate a duty cycle for the DC-DC converter by measuring PV output voltage and current. The maximum power is achieved by the suitable adjustment of duty cycles, which control the charging and discharging of the inductor and capacitors in the converter.

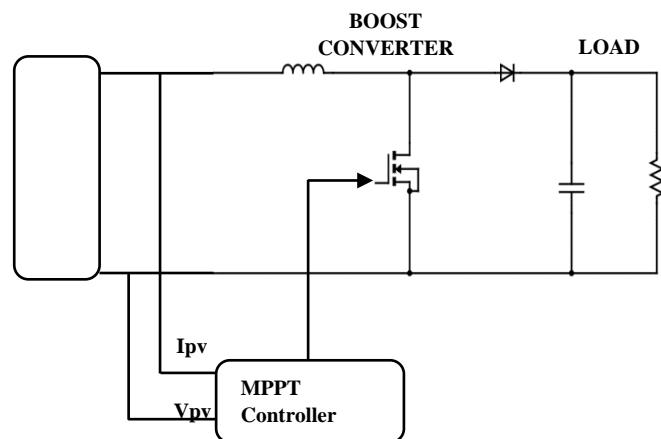

Fig. 1 The elements of solar power generation.

Generally, the MPPT techniques are classified into two categories: non-uniform irradiance and uniform radiance. The well-known non-uniform irradiance MPPT technique is Perturb and Observe (P&O) Method, Incremental Conductance (INC) Method, Hill Climbing (HC) Method and Current Sweep (CS) Method etc. the uniform irradiance MPPT technique uses artificial intelligence to achieve



maximum power. The well-known uniform irradiance MPPT techniques are neural network MPPT, Perturb and Observe with Genetic Algorithm, hybrid grey wolf optimization with a fuzzy logic controller, an artificial neural network with particle swarm optimization etc. However, these techniques are suffered from implementation costs and less tracking efficiency. Recently, the image processing-based solution has given promising results in automation, recognition, classification, etc. Deep learning (DL) based image processing techniques are a good candidate for automation. In this work, the DL model-based irradiance estimation is proposed for PV-MPPT to overcome the drawbacks of conventional MPPT techniques. The self-learned EfficientNetB0 deep learning model classifies the image captured from the camera. Then, the duty cycle is adjusted based on the irradiance level to achieve an MPPT.

The main objective of the proposed work is as follows:

- To propose a deep learning model-based irradiance estimation
- To increase a tracking speed
- To avoid communication between converters

This paper is structured in this fashion: In 2, the existing works related to MPPT are discussed. 3 describes the proposed deep learning-based MPPT. 4 presents the results & discussion part. 5 concludes the work.

2. Related work

Many researchers have applied MPPT methods to achieve optimal efficiency with low overhead and cost. Several MPPT methods are based on soft computing Approaches, such as fuzzy, neural networks etc. Lin et al. 2020 proposed a Group Searching Optimizer-based P&O to achieve maximum power. The fitness function for optimization is derived from voltage and current. Then, an optimizer is used to solve the fitness function. The proposed MPPT can decrease the steady state oscillations and improve the convergence speed.

Mohammed Salah Bouakkaz et al. developed a fuzzy integrated MPPT controller to handle sudden changes in climatic conditions. Fuzzification and de-fuzzification are applied in voltage and current parameters to adjust the duty cycles. A system's efficiency varies based on the type of membership used.

The multi-layered feed-forward network-based MPPT is proposed by Farhat, S.; et al. 2013 for maximizing efficiency. The neuron weight of each layer is adjusted to increase the tracking efficiency. The activation function of the sigmoid is integrated to propagate the importance of the data to the next layers. The complexity of the model increases when the number of layers increases. Padmanaban et al. 2019 developed a hybrid fuzzy and particle swarm

optimization-based controller for MPPT. To avoid a local minima problem in swarm optimization, the fuzzy logic is combined to set an initial population of the particles.

Several MPPT methods are based on image processing techniques, such as machine learning, deep learning, etc. Ye, Beijing et al. 2017 analyzed the behaviour of PV modules with shadow images. The local thresholding algorithm is used for image segmentation and shadow identification. The forecasting accuracy is considerably increased with the addition of image processing techniques to the PV system.

To avoid periodic curve scanning of conventional MPPT methods, the image-based irradiance estimation is proposed by Mahmoud et al. 2016. The response function of cameras is estimated by pixel processing, and irradiance level is predicted for duty cycle adjustments. Matlab implantation results show that the proposed approach increases 8% of efficiency when compared to existing methods. Hu proposes the concept of thermal imaging-based fault detection and irradiance prediction, Yihua et al. 2019. the faulty and healthy PV cells were identified and separated using thermal imaging. Also, the maximum power point is achieved through image-based temperature prediction.

Alsmad et al. 2020 proposed a new optical imaging-based MPPT for PV systems. The non-linear mapping of image pixels is utilized to control the DC-DC converter. Results show that the proposed method can extract the maximum power under partial shading conditions without any measurements.

3. Proposed image processing based MPPT

The block diagram of the proposed MPPT is shown in Figure 1. The image captured from the camera is used for irradiance estimation. The parameter-tuned DL model of EfficientNetB0 is applied for classification. The network model parameters are adjusted by tuna optimization to the error function.

3.1. Tuna Hunting Optimization (THO)

An optimization algorithm is used to solve complex and non-linear problems with decision-making. The real-world problems are framed as a fitness function and can be solved by identifying the best solution. Tuna optimization is a metaheuristic optimization developed to find the best solution in a search space inspired by hunting behavior. Tuna is a carnivorous marine fish with unique hunting behavior to catch prey. It follows two strategies to hunt the prey: Spiral Foraging and Parabolic Foraging. This Foraging behaviour is mathematically modelled to solve the problems. The steps of THO are as follows:

3.1.1. Initialization

The population are randomly generated as follows:

$$p_i^{int} = r(ul - ll) + ll, i = 1, 2, \dots, N \quad (1)$$

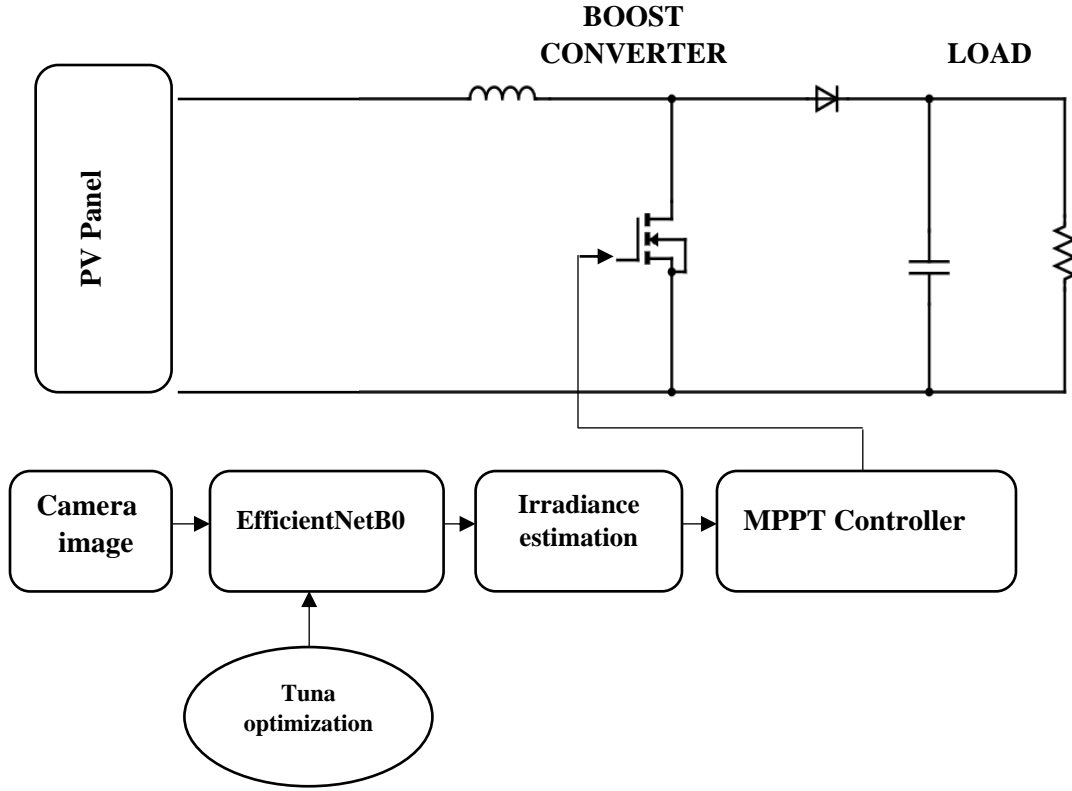

Fig. 2 Block diagram of proposed MPPT technique

Where P^{oint} is the position of an individual. ul and ll denote the upper and lower limit for solution search

3.1.2. Spiral Foraging

The group of tuna forms a tight spiral around the prey. This stage is considered an exploration stage of THO. The spiral foraging can be mathematically formulated as follows:

$$P_i^{t+1} = \begin{cases} c1. (P_{best}^t + c2. |P_{best}^t - P_i^t| + c3. P_i^t), & i = 1; \\ c1. (P_{best}^t + c2. |P_{best}^t - P_i^t| + c3. P_{i-1}^t), & i = 2,3...N \end{cases} \quad (2)$$

Where P_{best}^t is the best position to hunt prey, $c1$, $c2$, and $c3$ are coefficients used to control the movement and to avoid local minima problems.

3.1.3. Parabolic Foraging

In these stages, the tunas create parabolic regarding the target. This step is used to improve the global exploitation property of tuna optimization. The formation of parabolic mathematically modelled as follows:

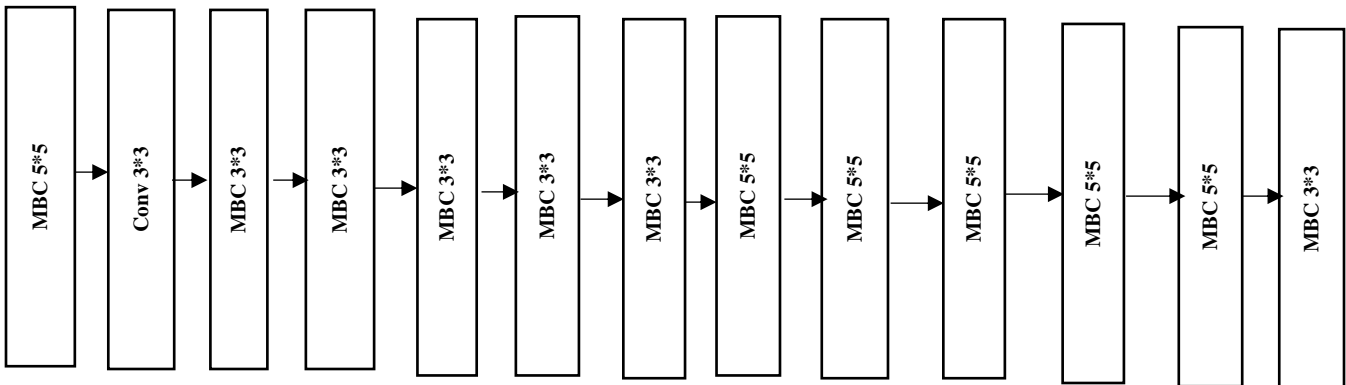

Fig. 3 Architecture of EfficientNetB0

$$P_i^{t+1} = \begin{cases} P_{best}^t + r1 \cdot (P_{best}^t - P_i^t) + r2 * s^2 * (P_{best}^t - P_i^t), \\ r2 * s^2 * P_i^t, \end{cases} \quad (3)$$

$$s = \left(1 - \frac{t}{t_{max}}\right)^{\frac{t}{t_{max}}} \quad (4)$$

Where r1 is the random number that varies between zero to one, and r2 is the random number that varies between 1 to -1.

3.2. EfficientNetB0

EfficientNetB0 is a type of CNN that follows a uniform scaling method to improve image classification performance. Unlike other models that use compound coefficients to scale the whole dimension of length and width uniformly. In addition, it extracts features from the image using multiple convolutional (MC) layers and the mobile inverted bottleneck Conv (MIBC). Increasing the parameters in the model will achieve higher accuracy levels, as shown in Figure 3. The parameters of the EfficientNetB0 model are tuned using tuna optimization

3.2.1. Hyperparameter Tuning in EfficientNetB0

The accuracy of the classification model depends on the values of the hyperparameter. EfficientNetB0 consists of two types of hyperparameters: network structure-based hyperparameters and learning parameter-based hyperparameters. This work learning parameter of epochs, learning rate and batch size is adjusted based on tuna optimization. The proper parameters are recognized through the use of a tuna swarm for achieving higher accuracy.

- Initialize EfficientNetB0 parameters.
- Initialize Tuna optimization parameters.
- Set P_i^{int} , ul, ll, c1, c2 and c3 parameters of optimization.

- Use the initial population to produce the EfficientNetB0 model.
- Calculate the error rate for the fitness function.
- Get the best solution having the least fitness in the population.
- Go to the last step of returning the best parameter when the criteria are satisfied; increment the number of iterations.
- Increment the number of iterations and update the population, go to create a model creating step again
- Return the best values parameter.

4. Experimental Results

The proposed classification model and MPPT technique are implemented using MATLAB. The panel and converter design parameters for simulation are given in table 1 & table 2. The proposed technique is compared against other conventional and intelligent techniques to evaluate performance.

Table 1. Parameters of PV system

MODEL -SunPower SPR-315E-WHT-D	
Maximum power(W)	500
Open circuit voltage(Voc)	13
Short circuit current (Isc)	5.8
The voltage at the maximum PowerPoint	12
Current, at the maximum PowerPoint	5.57
Temperature coefficient of Voc	-0.3131

Table 3. Efficiency analysis of proposed MPPT

Methods	Average power(W)	Voltage at MPP(V)	Current at MPP(A)	Tracking time (s)	Tracking efficiency (%)
P&O	222.5	89	2.5	0.76	58.9
Fuzzy	259.656	139.6	1.86	4.1	95.62
Swarm based optimizer	271.2	142.8	1.9	2.9	97.18
Proposed	279.3	147	1.9	0.81	98.67

Table 2. Parameters of the boost converter

Parameter	Values
Inductor (L)	960 mH
Capacitor (C)	960 μF
R	100 ohms

The performance of average time, tracking time and tracing efficiency is given in table 3. The results observed that the P&O-based approach traces a maximum power of 222.5 W with a tracking time of 0.76s. The Fuzzy based MPPT traces maximum power of 259.656 W with a tracking time of 4.1s. The Swarm-based MPPT traces maximum power of 271.2W with a tracking time of 2.9s. The proposed MPPT traces maximum power of 279.3W with a tracking time of 0.81s. The tracking efficiency performance of the proposed model is graphically shown in Figure.

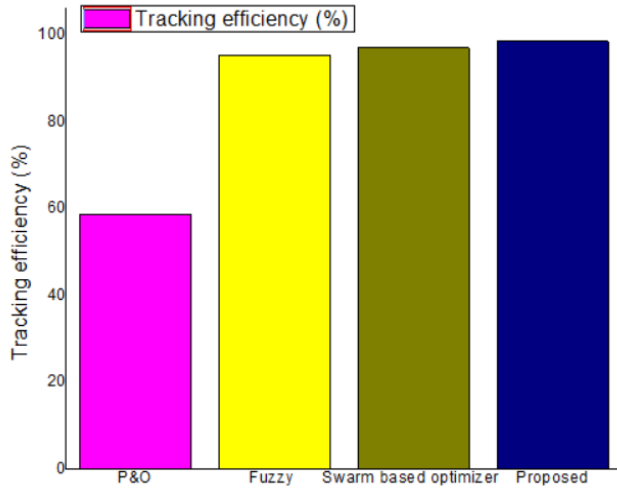

Fig. 4 Analysis of Tracking efficiency (%)

The proposed parameter-tuned EfficientNetB0 model is compared with other classifiers in terms of Accuracy (ACC), Specificity(SPC), Recall (REC) and Precision rate (PRE) as follows :

$$ACC = \frac{TP+TN}{(TP + TN+FP + FN')} \tag{5}$$

$$SPC = \frac{TN}{(TN + FP')} \tag{6}$$

$$REC = \frac{TP}{(TP + FN')} \tag{7}$$

$$PRE = \frac{TP}{(TP + FP')} \tag{8}$$

Where FP is the false positive, FN is the false negative; TP is the true positive, and TN is the true negative of the samples.

Table 4 observed that the proposed Optimized EfficientNetB0 model performs better in terms of all the parameters. The result attained in all iterations for ACC, PRE, REC, and SPE are 97.86 %, 96.89%, 97.4 % and 96.67 %, respectively. The performance of the proposed model is graphically shown in Fig. 5.

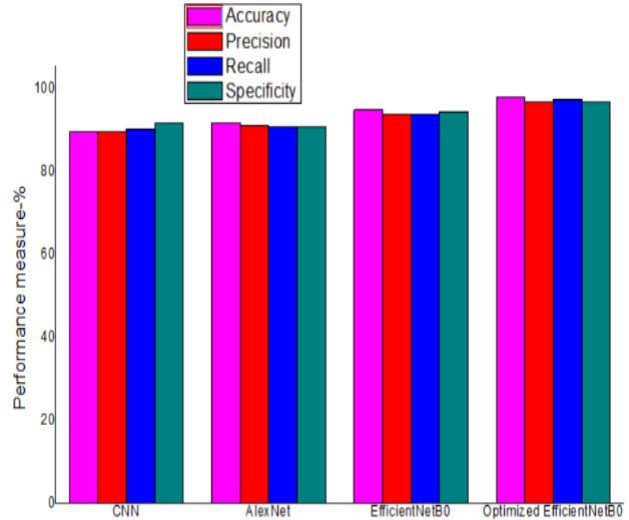

Fig. 5 Analysis of accuracy, precision, recall and specificity

Table 4. Classification performance of proposed and existing models.

Method	Accuracy	Precision	Recall	Specificity
CNN	89.62	89.5	90.2	91.6
AlexNet	91.8	91.2	90.8	90.95
EfficientNetB0	94.86	93.92	93.8	94.5
Optimized EfficientNetB0	97.86	96.89	97.4	96.67

5. Conclusion

To improve the conventional MPPT techniques, an optimized deep learning model-based irradiance estimation is proposed. The DL model of

EfficientNetB0 is combined with tuna optimization for better prediction results. The proposed model's classification results prove the model's better suitability for irradiance estimation. Further, the image-based approach shows better results regarding power efficiency, tracking time, etc.

References

- [1] Lin, Biyuan; Wang, Lei; Wu, Q. H, "Maximum Power Point Scanning for PV Systems Under Various Partial Shading Conditions," *IEEE Transactions on Sustainable Energy*, pp.1–1, 2020.
- [2] A. Bindhu, Dr. K. K. Thanammal, "Analytical Study on Digital Image Processing Applications," *SSRG International Journal of Computer Science and Engineering*, vol. 7, no. 6, pp. 4-7, 2020. Crossref, <https://doi.org/10.14445/23488387/IJCSE-V7I6P102>.
- [3] Mohammed Salah Bouakkaz;Ahcen Boukadoum;Omar Boudebbouz;Issam Attoui;Nadir Boutasseta;Ahmed Bouraiou; , "Fuzzy logic-based Adaptive Step Hill Climbing MPPT Algorithm for PV Energy Generation Systems," *2020 International Conference on Computing and Information Technology (ICCIT-1441)*, 2020.
- [4] Ho Soonmin, Masoud Taghavi, "Solar Energy Development: Study Cases in Iran and Malaysia," *International Journal of Engineering Trends and Technology*, vol. 70, no. 8, pp. 408-422, 2022. Crossref, <https://doi.org/10.14445/22315381/IJETT-V70I8P242>.
- [5] Farhat, S.; Alaoui, R.; Kahaji, A.; Bouhouch, L, "Estimating the photovoltaic MPPT by artificial neural network," [IEEE 2013 International Renewable and Sustainable Energy Conference (IRSEC) - Ouarzazate (2013.3.7-2013.3.9)], *International Renewable and Sustainable Energy Conference (IRSEC)*, pp.49–53, 2013.
- [6] Dr. V. Baby Deepa, R. Malathi "A Review of Image Processing In Different Techniques," *International Journal of Computer and Organization Trends* , vol.10, no.5, pp.12-15, 2020. Crossref, <https://doi.org/10.14445/22492593/IJCOT-V10I5P302>.
- [7] Padmanaban, Sanjeevikumar; Priyadarshi, Neeraj; Bhaskar, Mahajan Sagar; Holm-Nielsen, Jens Bo; Ramachandaramurthy, Vigna K.; Hossain, Eklas , "A Hybrid ANFIS-ABC Based MPPT Controller for PV System with Anti-Islanding Grid Protection: Experimental Realization," *IEEE Access*, pp.1–1, 2019. doi:10.1109/ACCESS.2019.2931547
- [8] Zakarya Benizza, Ahmed Mouhsen, Ezzitouni Jarmouni , "ANNs Based Unit for Power Control in a Micro Data Center," *International Journal of Engineering Trends and Technology* , vol.69, no.5, pp.6-10, 2021. Crossref, <https://doi.org/10.14445/22315381/IJETT-V69I5P202>.
- [9] Ye, Beijia; Qi, Jun; Li, Yuanhao; Xie, Luyao; Yang, Fan, "Research on PV array output characteristics based on shadow image recognition," [IEEE 2017 IEEE Conference on Energy Internet and Energy System Integration (EI2) - Beijing, China (2017.11.26-2017.11.28)], *IEEE Conference on Energy Internet and Energy System Integration (EI2)* , pp.1–6, 2017.
- [10] Manasa M, Dr. Sidheshwar Prasad, "Hybrid Model of Photovoltaic Power Plant for Electric Vehicle Charging System," *International Journal of Computer & organization Trends (IJCOT)*, vol.4, no.3, pp.90-95, 2014. Crossref, <https://doi.org/10.14445/22492593/IJCOT-V9P306>. ISSN:2249-2593.
- [11] Mahmoud, Yousef; El-Saadany, Ehab , "A Novel MPPT Technique based on an Image of PV Modules," *IEEE Transactions on Energy Conversion*, pp.1–1, 2016.
- [12] Hu, Yihua; Cao, Wenping; Wu, Jiande; Ji, Bing; Holliday, Derrick, "Thermography-Based Virtual MPPT Scheme for Improving PV Energy Efficiency Under Partial Shading Conditions," *IEEE Transactions on Power Electronics*, vol.29, no.11, pp. 5667–5672, 2014.
- [13] John Nweke, Arthur Ekwue, Emenike Ejiogu , "Economic Feasibility of Integrating Solar Photovoltaic Distributed Generation With Nigerian Power System," *International Journal of Recent Engineering Science*, vol.7, no.3, pp.61-71, 2020. Crossref, <https://doi.org/10.14445/23497157/IJRES-V7I3P113>.
- [14] Alsmadi, Mohammad; Mahmoud, Yousef, "Image-Based Differential Power Processing for Photovoltaic Microinverter," *IEEE Transactions on Energy Conversion*, pp.1–1, 2020.
- [15] N. E. Zakzouk, M. A. Elsharty, A. K. Abdelsalam, A. A. Helal, and B. W. Williams, "Improved performance low-cost incremental conductance PV MPPT technique," *IET Renewable Power Generation*, vol. 10, no. 4, pp. 561–574, 2016.
- [16] Niharika Agrawal, and Mamatha Gowda."Power Flow Enhancement by TCSC using Two Different Types of Pulse Generators" *International Journal of Recent Engineering Science* , vol. 9, no. 1, pp. 31-38, 2022. Crossref, <https://doi.org/10.14445/23497157/IJRES-V9I1P105>.
- [17] D. C. Huynh and M. W. Dunnigan, "Development and Comparison of an Improved Incremental Conductance Algorithm for Tracking the MPP of a Solar PV Panel," *IEEE Transactions on Sustainable Energy*, vol. 7, no. 4, pp. 1421–1429, 2016.
- [18] K.Kiruthiga, A.Dyaneswaran, B.Kavitha, Dr.R.Prakash ." A Grid Connected Hybrid Fuel Cell-PO Based MPPT for Partially Shaded Solar PV System," *International Journal of P2P Network Trends and Technology (IJPTT)*, vol.4, no.2, pp.42-46, 2014. ISSN:2249-2615,
- [19] 11 M. A. Elgendy, D. J. Atkinson, and B. Zahawi, "Experimental Investigation of the Incremental Conductance Maximum Power Point Tracking Algorithm at High Perturbation Rates," *IET Renewable Power Generation*, vol. 10, no. 2, pp. 133–139, 2016.
- [20] T. Esmar and P. L. Chapman, "Comparison of Photovoltaic Array Maximum Power Point Tracking Techniques," *IEEE Trans. Energy Convers.*, vol. 22, no. 2, pp. 439–449, 2007.